



LAVACA-NAVIDAD RIVER AUTHORITY
EDNA, TEXAS

WEST DIKE STORAGE FACILITY
BID FORM AND SPECIFICATIONS

Thursday, March 6, 2025, at 10:00 a.m.

LAVACA-NAVIDAD RIVER AUTHORITY
P.O. Box 429
4631 FM 3131
Edna, TX 77957

REQUEST FOR BIDS
for
WEST DIKE STORAGE FACILITY

Instructions to Bidders

The Lavaca-Navidad River Authority is seeking bids for the fabrication, erection, and installation of a 30' X 420' metal building with 120' portion of the 420' total length being fully enclosed and the remainder (300') will be a lean-to configuration. The enclosed area will be on a secured to a concrete foundation and the lean-to section will be on concrete piers. The storage facility is located at LNRA's west dike.

1. Sealed bids addressed to the Lavaca-Navidad River Authority (LNRA), P. O. Box 429, Edna, Texas, 77957, and labeled as "**BID – West Dike Storage Facility**" will be received at the Lavaca-Navidad River Authority office located at 4631 FM 3131, Jackson County, Texas, until March 6, 2025, at 10:00 a.m. No late or faxed bids will be considered. The Authority will proceed without unnecessary delay to consider all bids submitted and reserves the right to reject any and/or all bids.
2. Bids shall be submitted on the Bidding Schedule provided or copies thereof and signed. The Bidder must enter a bid for each item on the Bidding Schedule for his bid to be considered acceptable. The total bid submitted shall include all costs for the complete conduction of services, inclusive of labor and equipment.
3. Bids must be properly sealed, marked as a sealed bid and include the name and address of the bidding party. Withdrawal or modification of bids must occur before the bid opening.
4. All bidders are hereby advised that a mandatory site visit is required to determine whether any conditions exist which would affect the work or the cost thereof in any way. Upon receipt of the bid, each bidder will be held responsible for knowing the conditions as they exist.
5. Before a bid proposal is considered for award, the bidder may be asked to submit a statement regarding his previous experience in performing comparable work, his organization, financial resources, and equipment available for performing the work.
6. All bids will be opened at the time stated and at the above address. The results of the bid opening will be available after that time.
7. Bids shall be submitted on the Bidding Schedule provided or copies thereof and signed. The Bidder must enter a bid for each item on the Bidding Schedule for his bid to be considered acceptable. The total bid submitted shall include all costs for the complete conduction of services, inclusive of labor, equipment and supervision.

8. The contractor awarded the contract shall begin work at a time designated by the LNRA.
9. The Successful Bidder should refer to the Texas Code Section 151 and if there are any conflicts or questions, contact the Texas Comptroller's Office. This Contract is issued by an agency which qualifies for exemption pursuant to the provisions of Section 151.309 of the Tax Code of the State of Texas.
10. To receive payment, the Contractor will prepare a statement showing as completely as practicable the total value of the work done by the Contractor. The LNRA will review and approve the statement before payment will be made. Each invoice should include hours, price per hour, and total cost per job. LNRA will inspect the progress on a random basis to ensure the work is complete and satisfactory. All invoices will be paid within 30 days after the invoice arrives at the LNRA office and at the rate specified on the bid sheet attached hereto.
11. The terms "LNRA" and "Contractor" are defined in the contract and specifications as follows:

The LNRA is the Lavaca-Navidad River Authority represented by the General Manager.

The Contractor is the party contracting directly with the LNRA to furnish equipment and perform services in accordance with the Contract Documents.

**LAVACA-NAVIDAD RIVER AUTHORITY
WEST DIKE STORAGE FACILITY
BIDDING SCHEDULE**

SCOPE OF SERVICES

Contractor will supply equipment, labor, materials, and superintendence required for the fabrication, erection and installation a 30' X 420' metal building with 120' portion of the 420' total length being fully enclosed and remainder (300') being a lean-to configuration as described in the general notes on Drawing A-1. The enclosed area will have a concrete foundation, and the remainder lean-to section shall be placed on concrete piers, as specified in the general notes on Drawing A-2. Refer to Drawing A-1 and A-2 for additional details. The storage facility will be located at LNRA's west dike. Contractor is hereby advised that a mandatory site visit will be required to bid on this project to ensure each bidder is familiar with the work.

The following technical specifications should be considered. Variances from these specifications shall be clearly noted on the bids.

30' x 420' building with 120' portion of the 420' total length being fully enclosed as specified below:

Roof Pitch	Single Slope
Eave height	Match existing
Roof Panels	24 ga. Galvalume R Panel
Sidewall Panels	26 ga. Galvalume R Panel
Over Head Doors	(4) 12' x 12' OH Roll Up Doors
Walk Doors	(4) 3070
Windows	None
Gutters and Downspouts	Not Included
Insulation	Enclosed 30' x 120' portion
Fabricated Framing	Galvanized
Gauged Framing	Galvanized
Concrete	3000 psi.

Contractor

Prior to beginning any work, Contractor shall provide proof of insurance, to include worker's compensation, and shall have Lavaca-Navidad River Authority listed as additional insured on the Contractor's insurance policy. Additionally, Contractor shall provide a copy of their W-9 to LNRA at the address listed above.

A General Services Contract must be signed by both Contractor and LNRA before any work begins. Contractor assumes full responsibility for completing the contract under these conditions.

Equipment

Contractor is required to supply all equipment, labor, and materials needed to complete the job. A project superintendent will be required on site at all times.

Bid Form

<u>Item No.</u>	<u>Description</u>	<u>Basis</u>	<u>Total</u>
1.	Fabrication, erection, and installation of a 30' X 420' metal building with 120' portion of the 420' length being fully enclosed and remainder (300') being partially sheeted as specified in the Scope of Services and detailed in Drawings A-1 and A-2.	LS	\$ _____
	TOTAL BID		\$ _____

The undersigned, as bidder, declares that he has carefully examined the Instructions to Bidders, Bidding Schedule, Bid Form Contract, Specifications, contract work locations, and General Services Contract.

The undersigned certifies that these amounts bid have been carefully checked and are submitted as correct and final.

The Lavaca-Navidad River Authority reserves the right to refuse any and/or all bids.

Please mark your sealed bid “**BID – Lavaca-Navidad River Authority West Dike Storage Facility**”.

Signature

Date

Title

Printed Name of Signatory

CONTRACT SPECIFICATIONS

1. Investigation of Site Conditions

Bidders are required to visit the site of the work and must be accompanied by and LNRA representative and by their own investigations satisfy themselves as to the existing conditions affecting the work to be done under these specifications. Bidders may contact Scott Hartl, P.E. at 361-782-5229 during regular business hours to request a site visit.

2. Qualifications of Bidder

Prior to award of contract, the bidder shall submit such evidence as required by the LNRA to establish the bidder's qualifications to satisfactorily perform the work included in this project. Information that may be required shall include:

- (1) the bidder's current financial statement including amount of funds readily available to commence and carry out the work;
- (2) a list of equipment available for this project;
- (3) a list of projects that have been satisfactorily completed by the bidder within the last five years that are the same general type as included in this contract, together with the names, addresses and phone numbers of persons familiar with this work;
- (4) other information that may be pertinent to the bidder's qualifications;
- (5) a designated Superintendent or contact person; and
- (6) Insurance Agent(s) telephone and address.

Should the bidder fail to promptly produce evidence satisfactory to the Authority on any of the foregoing points he may be disqualified, and the work awarded to the next bidder so qualifying.

3. Award

The LNRA will proceed without unnecessary delay to consider the bidding schedules and reserves the right to reject any or all bids. Date of award is the date of the LNRA decision to award the Contract to the selected bidder. The award of the Contract will be made by the LNRA Board of Directors to the responsible party whose bid is most advantageous to the LNRA.

4. Rejection of Bids

The LNRA reserves the right to reject any bidder if investigation of such bidder fails to satisfy the LNRA that such bidder is properly qualified to carry out the obligations and to complete the work contemplated by Contract Documents. Any or all bids will be rejected if there is reason to believe that collusion exists among the bidders.

5. Failure to Execute Contract

Should the successful bidder fail to execute the Contract and to validate the same within 10 days after award of Contract, the award shall go to the next lowest bidder if approved by the Authority.

6. Contractor's Insurance

- A. The Contractor shall not commence work under the Contract until he has obtained at his expense all insurance required by the Contract Documents and such insurance has been approved by the LNRA. Such insurance shall remain in full force and effect on all phases of the work, until all work under the Contract is completed and has been accepted by the LNRA.
- B. Contractor shall procure and maintain for the term of the Contract insurance that is required by law, including workers compensation, with the following limits:
 - 1. General Liability \$1,000,000
 - 2. Automobile Liability \$1,000,000
 - 3. Workers Compensation \$1,000,000
- C. Before commencement of any work, the Contractor shall submit written evidence that the minimum insurance required by the Contract Documents has been obtained. Such written evidence shall be in the form of a Certificate of Insurance executed by the Contractor's insurance carrier showing such policies in force for the specified period or by furnishing a copy of the actual policy or policies. Each certificate shall contain an endorsement or statement waiving right of cancellation or reduction in coverage unless 30 days prior written notice is given to the LNRA by registered or certified mail, and, in regard to the liability policy, shall specifically state that the LNRA is named as an insured party.

7. Indemnity

To the extent permissible by law, the Contractor shall protect, defend, indemnify, and save harmless the LNRA, and its officers, agents, and employees, from and against suits, actions, claims, losses, liability or damage of any character, and from and against costs and expenses, including attorney fees, incidental to the defense of such suits, actions, claims, losses, damages or liability on account of injury, disease, sickness, including death, to any person, or damage to property.

The Lavaca-Navidad River Authority shall not be held responsible for any damage to vehicles, equipment or other property or for any personal injuries caused by the Contractor. The Contractor will also be responsible for any damage to Contractor's equipment or injuries to Contractor's employees.

8. Payment

After a statement is prepared by the Contractor showing as completely as possible the total value of the work done by the Contractor, the LNRA will review and approve the statement before the lump sum payment will be made. LNRA will inspect the progress on a random basis to ensure the work is complete and satisfactory. All invoices will be paid within 30 days after the invoice arrives at the LNRA office and at the rate specified on the bid sheet attached hereto.

9. Cancellation

This contract may be cancelled at any time by either party upon giving the other party at least thirty (30) days prior written notice of the intended date of cancellation.

10. Notices

All notices, requests, demands, and other communications shall be sent to:

If to LNRA:

Lavaca-Navidad River Authority
P.O. Box 429
Edna, Texas 77957

If to Contractor:

11. Information

To obtain additional information regarding these specifications, please contact:

Scott Hartl, P.E.
Assistant Manager of Operations
361-782-5229

GENERAL SERVICES CONTRACT

This Contract for Services is made effective as of _____, by and between Lavaca-Navidad River Authority (“LNRA”) and _____ (“Contractor”).

1. DESCRIPTION OF SERVICES

Contractor will supply equipment, labor, materials, and superintendence required for the fabrication, erection and installation a 30’ X 420’ metal building with 120’ portion of the 420’ total length being fully enclosed and remainder (300’) being a lean-to configuration as described in the general notes on Drawing A-1. The enclosed area will have a concrete foundation, and the remainder lean-to section shall be placed on concrete piers, as specified in the general notes on Drawing A-2. The storage facility will be located at LNRA’s west dike.

2. PAYMENT FOR SERVICES

A lump sum payment shall be made to Contractor upon completion of Services by providing a detailed invoice, including equipment, labor, materials and superintendence. Contractor shall also provide a copy of Form W-9. All invoices will be paid within 45 days of receipt by LNRA, and should be mailed to the address below:

Lavaca-Navidad River Authority
Attn: Accounting
P.O. Box 429
Edna, TX 77957

3. TERM

This Contract will terminate automatically upon Contractor’s completion of Services required by this Contract.

4. INSURANCE

Contractor shall procure and maintain for the term of the Contract insurance that is required by law, including workers compensation, with the following limits:

- | | |
|-------------------------|-------------|
| 4. General Liability | \$1,000,000 |
| 5. Automobile Liability | \$1,000,000 |
| 6. Workers Compensation | \$1,000,000 |

No work shall commence under this Contract until Contractor has obtained, at their own expense, all insurance and such insurance has been approved by LNRA. Such insurance shall remain in full force and effect on all phases of the work, until all work under the Contract is completed and has been accepted by LNRA.

5. INDEMNIFICATION

To the extent permissible by law, Contractor shall protect, defend, indemnify, and save harmless LNRA, and its officers, agents, and employees, from and against suits, actions, claims, losses, liability or damage of any character, and from and against costs and expenses, including attorney fees, incidental to the defense of such suits, actions, claims, losses, damages or liability on account of injury, disease, sickness, including death, to any person, or damage to property.

LNRA shall not be held responsible for any damage to vehicles, equipment or other property or for any personal injuries caused by the Contractor. The Contractor will also be responsible for any damage to Contractor's equipment or injuries to Contractor's employees.

6. AMENDMENT

This Contract may be modified or amended in writing by mutual agreement of both parties.

7. TERMINATION

This Contract may be terminated at any time by either party upon giving the other party at least thirty (30) days prior written notice of the intended date of termination.

8. NOTICES

All notices, requests, demands, and other communications shall be sent to:

If to LNRA:

Lavaca-Navidad River Authority
P.O. Box 429
Edna, TX 77957

If to Contractor:

Attn: _____

9. MISCELLANEOUS:

CONTRACTOR HAS COMPLETED FORM 1295 INCLUDING OBTAINING THE CERTIFICATION OF FILING NUMBER, AND IT HAS BEEN FILED WITH OWNER, IN COMPLIANCE WITH GOVERNMENT CODE 2252.908 AS PRESCRIBED BY LAW.

Consistent with Govt. Code Chapter 2270, by signing below, CONTRACTOR hereby verifies that CONTRACTOR does not boycott Israel and will not boycott Israel during the term of this Contract.

IN WITNESS WHEREOF, the parties hereto have caused this Contract to be executed by their duly authorized representative as of the date first written above.

Lavaca-Navidad River Authority
General Manager

Contractor

Signature

Signature

Printed Name

Printed Name

Date

Date

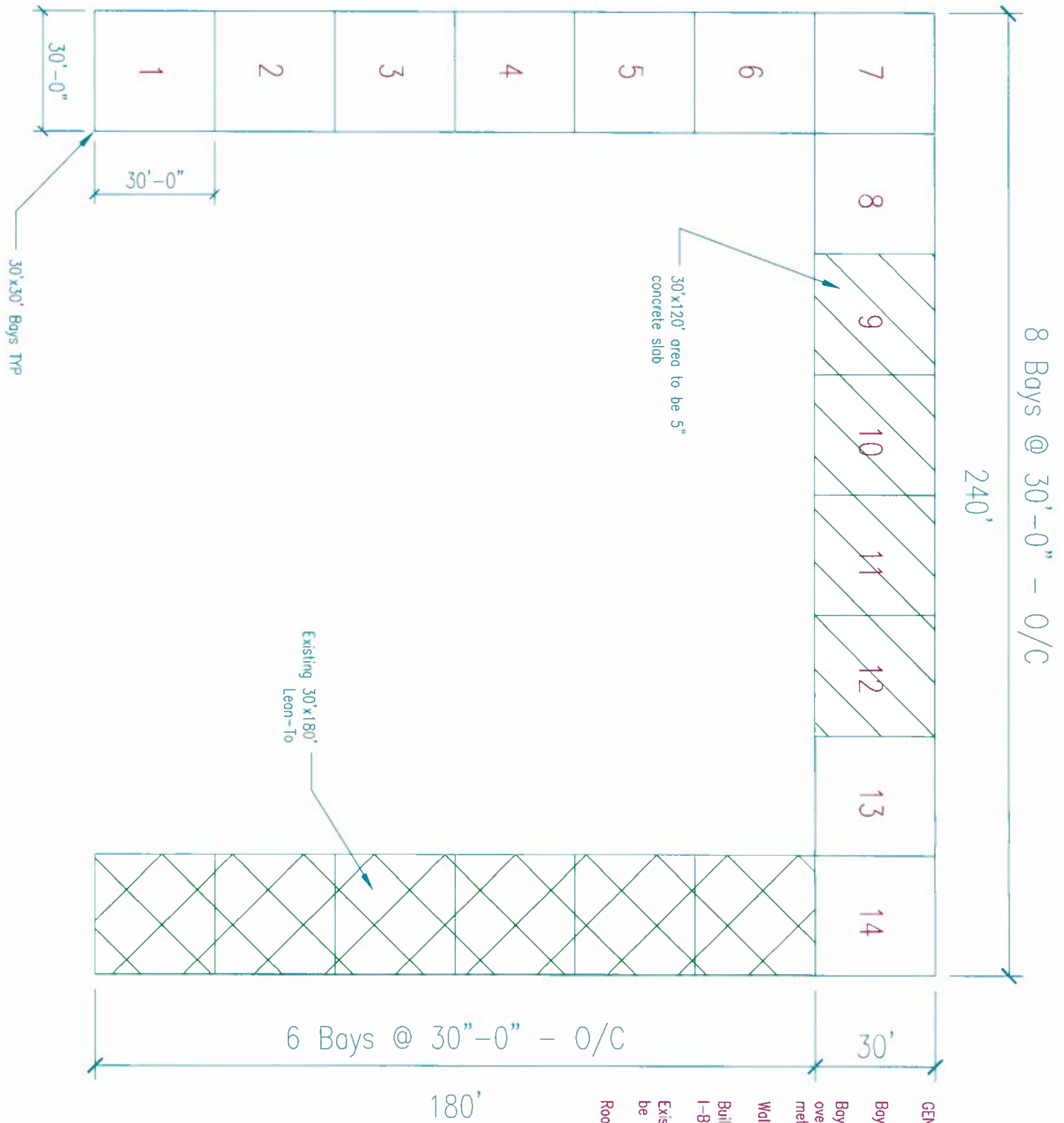

GENERAL NOTES:

Boys 1 thru 14 will be new construction

Boys 9 thru 12 will be fully enclosed. Insulate ceiling and walls and include a 12'x12' overhead door and 3'x7' man door in each bay. The 30' boys will be separated by a metal stud wall with tin on one side

Wall sheets and roof sheets to match existing

Building construction will include 4" galvanized schedule 40 columns with 10" 15lb/LF I-Beam rafters and 10" purlins and girts. All building components shall be galvanized.

Existing 30'x180' Lean-To to remain. Some modifications to the existing structure will be necessary to tie in the new construction.

Roof material shall be 24 GA. Wall panels shall be 26 GA.

REVISIONS		
Date	Description	Approved

LNRA
Lavaca-Navidad River Authority

West Dike Storage Facility
ADDRESS CITY-STATE
Drawing A-1

Designed DESIGNER D-DATE
Drawn DRAFTER DR-DATE
Checked CHECKER C-DATE
Approved _____ Date _____
Title _____ Job Class JC

File No.
CAD_FILE_NAME
CAD_FILE_NAME1
Sheet SH of TS

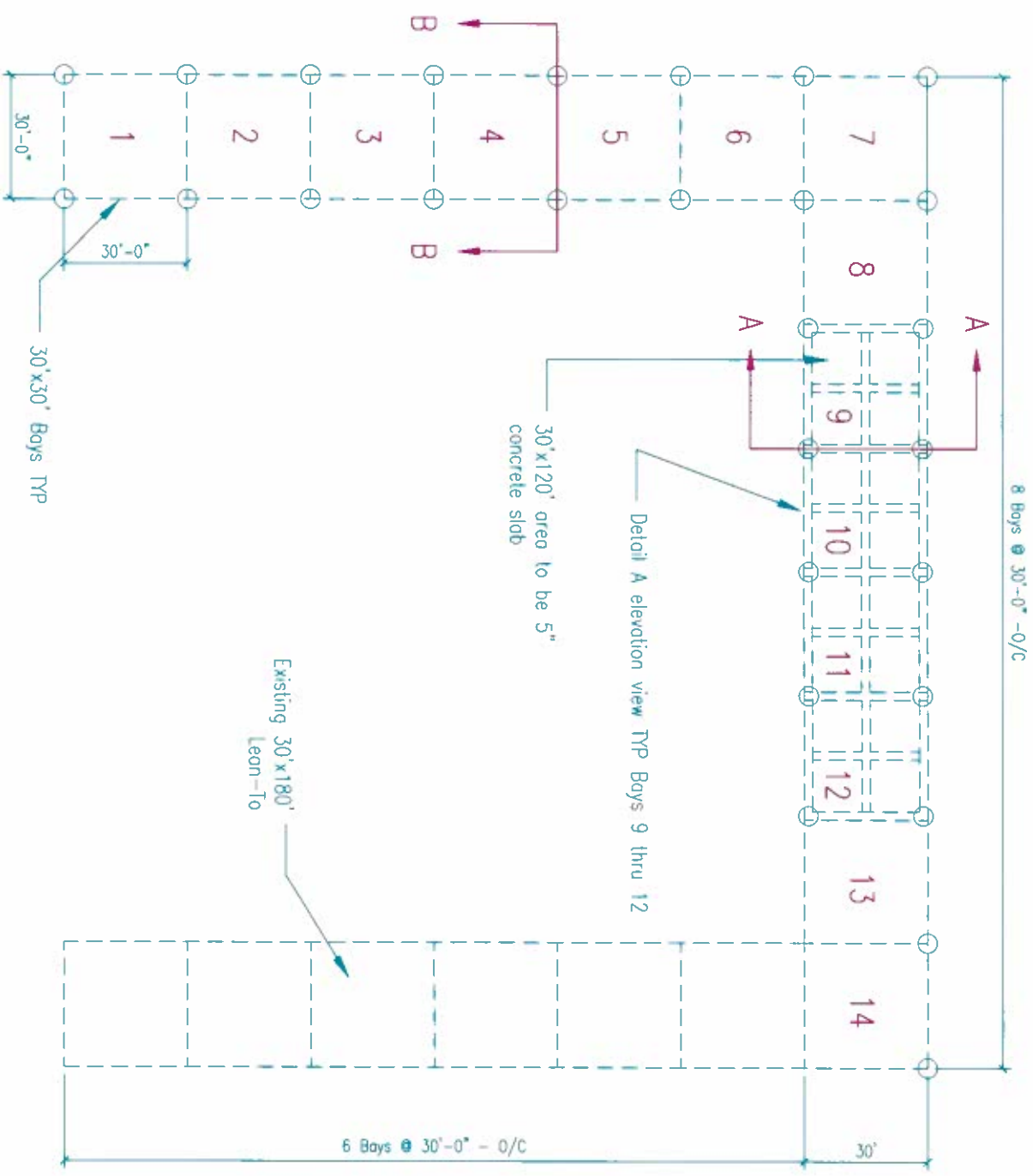

GENERAL NOTES:

30'x120' occupying boys 9, 10, 11, and 12 slab to be 5" thick with a #3 rebar mat on 12" centers and a perimeter beam of 12"x24" with #3 stirrups on 24" centers with #4 rebar tied in all four corners of the stirrup. Interior beams of 12"x18" with #3 stirrups on 24" centers and #4 rebar tied in all four corners of the stirrup. Interior beams to be spaced 15' EW. Interior beam steel shall tie into column steel.

Shoifs for the free standing columns shall be 18" dia x 8' and the shoifs for boys 9, 10, 11, and 12 shall be 18" dia x 5'. Shoifs lengths start at the ground surface elevation. Shoif steel shall be 14" #3 continuous spiral steel on 12" centers. Six #4 sticks of rebar shall run the length of the shoif and be evenly spaced around the circumference of the 14" spiral.

Weld plates for shoifs shall be 8"x8"x 1/2" plate with four 12" J-Bolt anchors. Contractor shall set/place weld plates on shoifs while concrete is still fresh.

Existing 30'x180' Lean-To to remain. Contractor will accommodate modifications to the existing structure that are necessary to tie in the new construction.

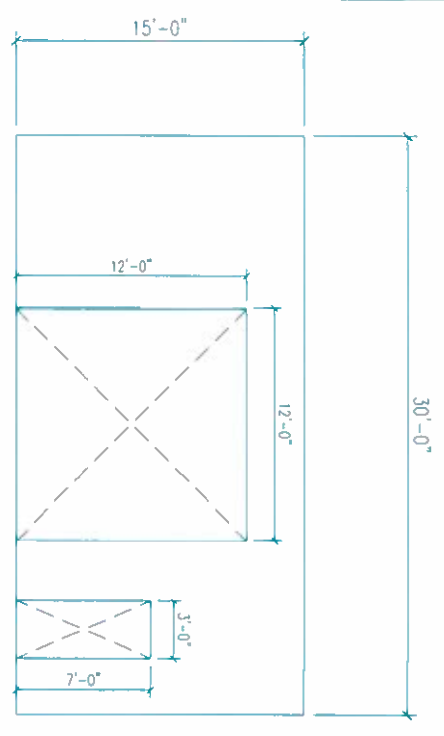

NOTES:

12'x12' Overhead Type door

3'x7' man door shall be steel painted white

Detail A

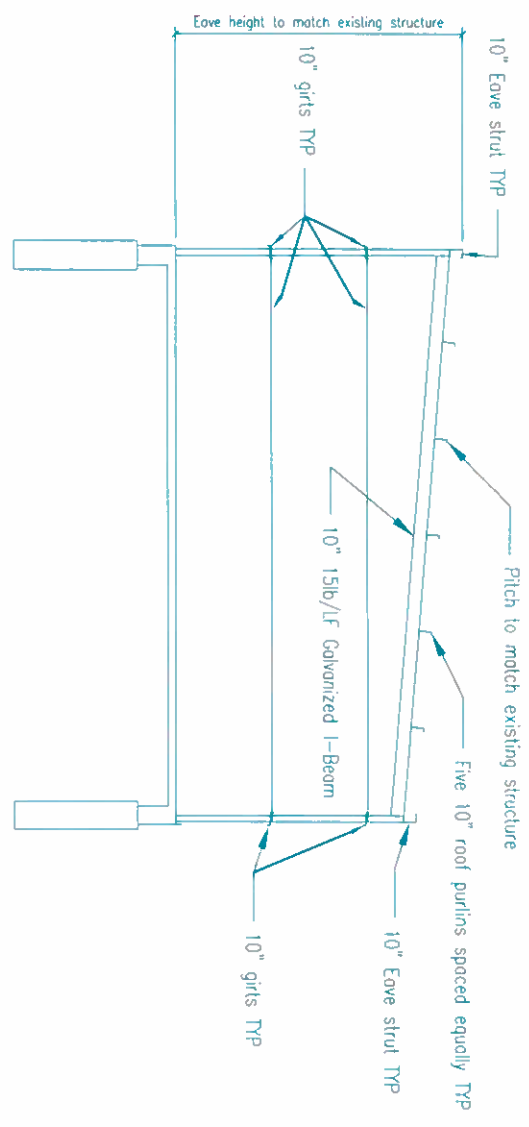

Section A-A

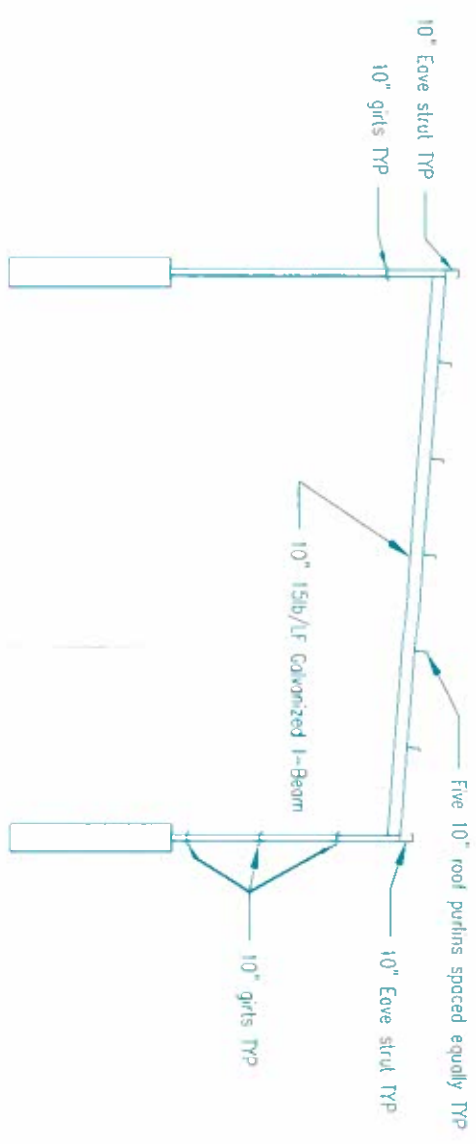

Section B-B

LNRA Lavaca-Navidad River Authority			West Dike Storage Facility		Designed DESIGNER D-DATE	
			ADDRESS CITY-STATE		Drawn DRAFTER DR-DATE	
			Drawing A-2		Checked CHECKER C-DATE	
			Approved _____ Date _____		Title _____ Job Class _____	

REVISIONS		
Date	Description	Approved

File No. _____
 CAD FILE NAME _____
 CAD FILE NAME1 _____
 Sheet SH of TS _____